

DIMENSIONS • MASSE • DIMENSIONS

U 61

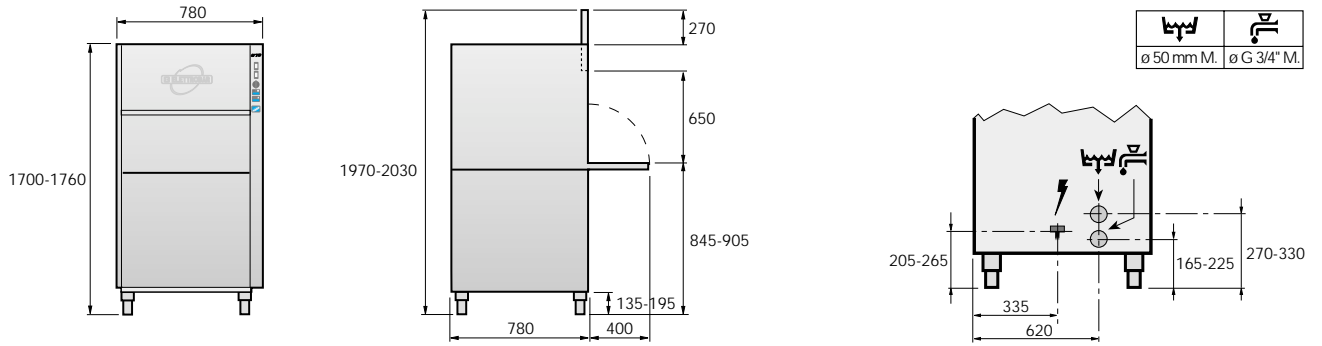

U 61H

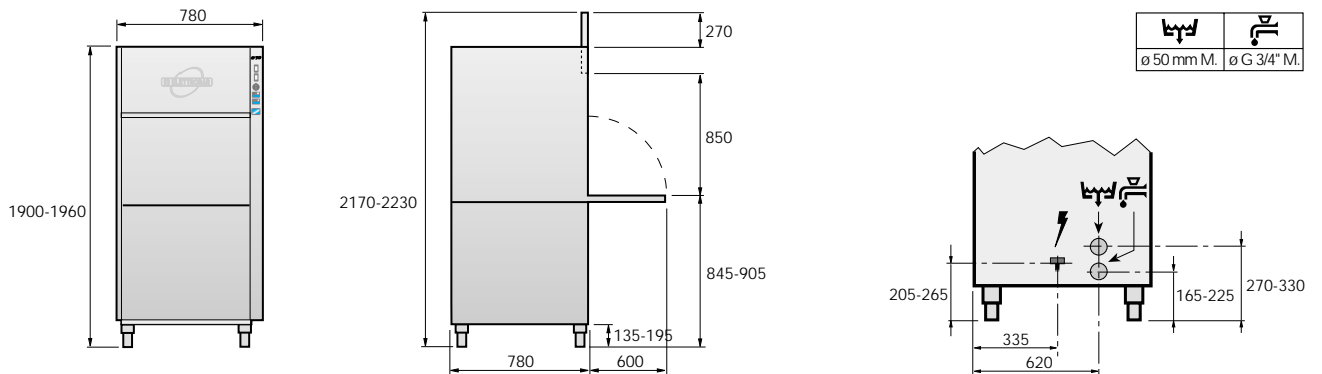

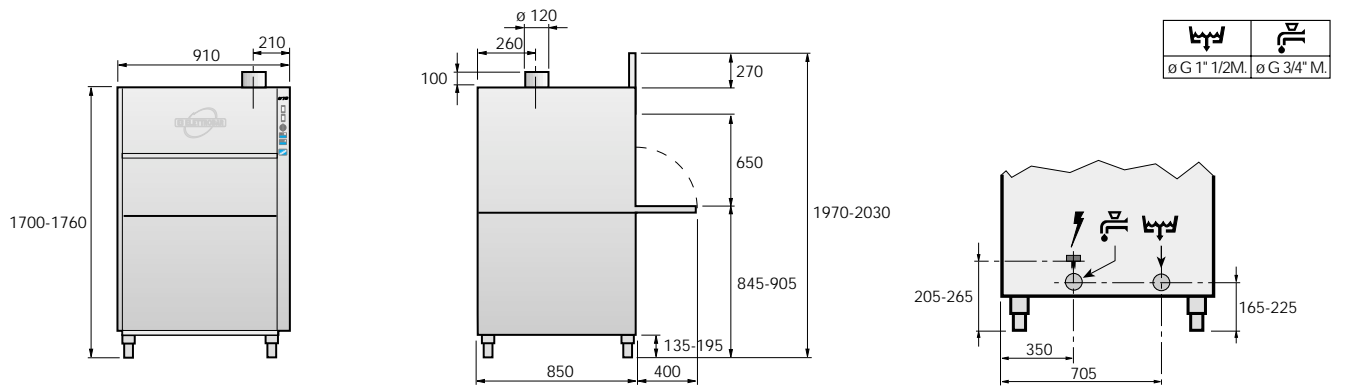

U 70

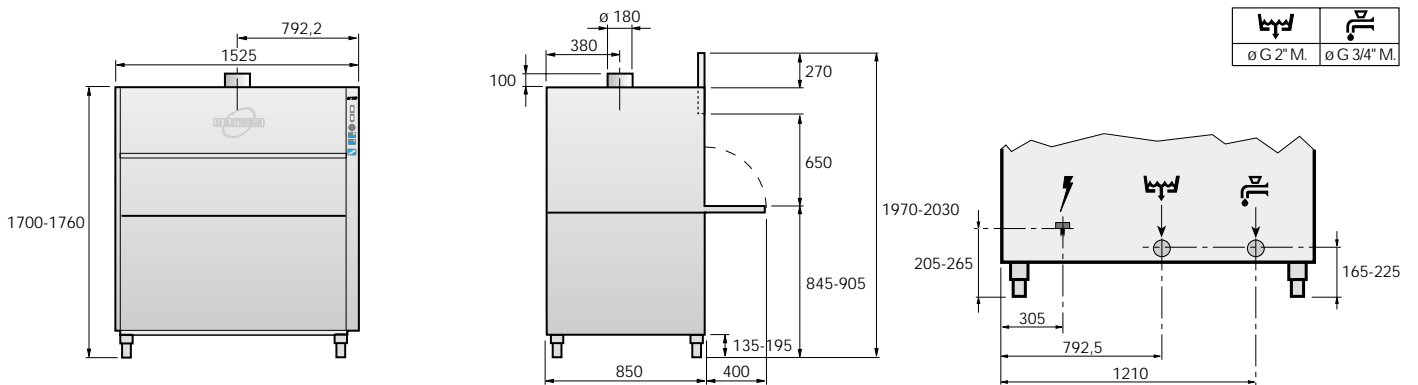

U 132



				U 61	U 61H	U 70	U 132
- Electrical rating	Alimentation électrique	Stromversorgung	Volt/Hz	400/3~ +N/50 230/3~/50		400/3~ +N/50	
- Maximal used power	Puissance max. absorbée	Gesamtanschlußwert	kW	7,4	8,0	11,0	15,0
- Baskets /h	Paniers /h	Körbe /Std.	n°	30 - 15 - 10			
- Total wash cycles/Booster	Durée totale du cycle de lavage/ Surchauffeur	Spülprogrammdauer /Nachspülboiler	sec.	120 - 240 - 360/20			
- Wash pump	Electropompe de lavage	Wasserpumpe	kW	1,4	2,0	3,0	2 x 3,0
- Rinse pump	Electropompe de rinçage	Klarspülungpumpe	kW	0,15	0,15	0,45	0,45
Heating elements • Résistances • Heizungen							
- Tank	Cuve	Tank	kW	3,0	3,0	6,0	6,0
- Booster	Surchauffeur	Nachspülboiler	kW	6,0	6,0	8,0	9,0
Temperature • Temperature • Temperatur							
- Tank	Cuve	Tank	°C	55	55	55	55
- Booster	Surchauffeur	Nachspülboiler	°C	85	85	85	85
Heater capacity • Capacité • Inhalt							
- Tank	Cuve	Tank	l	40	40	65	130
- Booster	Surchauffeur	Nachspülboiler	l	14	14	14	14
- Water consumption for cycle	Consommation d'eau pour cycle	Wasserverbrauch pro Spülvorgang	l	3,5	3,5	4	8
Feeding water • Eau d'alimentation • Fließwasser							
- Temperature	Température	Temperatur	°C	15...55	15...55	15...55	15...55
- Hardness	Dureté	Wasserhärte	°f	5...10	5...10	5...10	5...10
- Pressure	Pression	Druck	bar	2...4	2...4	2...4	2...4
- Baskets	Paniers	Körbe	mm	550x610		700x700	1320x700
- Net/gross Weight	Poids net/brut	Netto-/Brutto Gewicht	kg	115/145	120/150	123/155	140/175
- Supplied racks	Paniers standard	Korbausstattung		1 x 			
- Supplied hose	Tuyau standard	Schlauchausstattung					
On request • Sur demande • Auf Wunsch							
- Detergent dispenser • Doseur de produit de lavage • Spülmitteldosierer - Rinse aid dispenser • Doseur produit de rinçage • Klarspüldosierer							

1 bar = 100 kPa

Guarantee 12 months excluding electrical parts • Garantie 12 mois sauf composants électriques • Garantie 12 Monate, elektrische Teile ausgeschlossen.
 Continual improvements may supersede specifications • Les caractéristiques techniques peuvent être modifiées sans préavis • Technische Änderungen vorbehalten.